

INSTRUCTIONS

GOTCHA® PLUS INSTALLATION

RAB®

RAB Lighting is committed to creating high-quality, affordable, well-designed and energy-efficient LED lighting and controls that make it easy for electricians to install and end users to save energy. We'd love to hear your comments. Please call the Marketing Department at 888-RAB-1000 or email: marketing@rablighting.com



GT500



GT500R

IMPORTANT

READ CAREFULLY BEFORE INSTALLING FIXTURE. RETAIN THESE INSTRUCTIONS FOR FUTURE REFERENCE.

RAB fixtures must be wired in accordance with the National Electrical Code and all applicable local codes. Proper grounding is required for safety. THIS PRODUCT MUST BE INSTALLED IN ACCORDANCE WITH THE APPLICABLE INSTALLATION CODE BY A PERSON FAMILIAR WITH THE CONSTRUCTION AND OPERATION OF THE PRODUCT AND THE HAZARDS INVOLVED.

WARNING: Make certain power is OFF before installing or maintaining fixture. No user serviceable parts inside.

WARNING: To prevent wiring damage or abrasion, do not expose wiring to edges of sharp objects.

SPECIFICATIONS

GT500:

Voltage: 120V–277VAC, 60Hz

UL Listing: Suitable for wet locations, raintight.

Time Adjustment: 5 sec. to 15 min.

Test Mode: Set Time Adjustment Knob on sensor to Test Mode

Switching Capacity:

500W @120VAC Tungsten

500W @277VAC Tungsten

600W @120VAC Electronic Ballast (LED)

1350W @277VAC Electronic Ballast (LED)

Power Consumption: 4 Watts

Surge Protection: 6 kV

Operating Temperature: -4°F to 104°F (-20°C to 40°C)

Detection Zone: 110° by 50' at 8' mounting height

Warm Up Period: 60 seconds

Sensitivity Adjustment: 100% to 50%

Sensor Construction: Watertight, precision-molded polycarbonate

Sensor Adjustment: +/- 20° pan and tilt

GT500R:

PAR Holder Construction: Precision molded polycarbonate with molded gasket

Cover Plate Construction: Die-cast aluminum universal coverplate for surface or recessed junction box mounting

Sockets: Medium Base

Lamps: 150W Max PAR 38, *not supplied*

CONTENTS

GT500 contents: (Fig 1)

1. (3) Wire Nuts
2. Sensor



Fig: 1

GT500R contents: (Fig 2)

1. Sensor assembled with (2) PAR holders with molded gaskets on a universal cover plate, wired.
2. Plate with foam gasket
3. EZ Hang "S" Hook
4. Crossbar
5. Mounting screws, ground screw, plastic finishing cap
6. (3) Wire Nuts



Fig: 2



INSTRUCTIONS

GOTCHA® PLUS INSTALLATION



RAB Lighting is committed to creating high-quality, affordable, well-designed and energy-efficient LED lighting and controls that make it easy for electricians to install and end users to save energy. We'd love to hear your comments. Please call the Marketing Department at 888-RAB-1000 or email: marketing@rablighting.com

OVERVIEW

How Does Gotcha® Work?

The Gotcha infrared sensor “sees” small temperature changes caused by the motion of people or cars within its Detection Zone and turns on lights automatically. It welcomes visitors and may deter intruders.

How long do the lights stay on?

Lights remain on as long as there is movement within the Detection Zone. Once the zone is vacated, lights will remain on approximately 5 sec. up to 15 min., depending on the time control adjustment. During initial 60 sec warm-up time, lights remain on.

Will the sensor detect animals?

Gotcha may detect large animals. You can limit animal detection by turning down sensitivity knob or by placing opaque weatherproof tape on the lower part of the lens. (Fig 3)



Fig: 3

GT500R KIT MOUNTING

MOUNTING TO SURFACE JUNCTION BOX

Gotcha floodlight kits come pre-wired and assembled on the RAB CU4 EZ plate, allowing for mounting on round, rectangular or octagonal surface or recessed box.

1. Attach **Cross Bar** to **Surface Junction Box** using three bar screws (*supplied*). (Fig 4)
2. Bring sensor wires through the **Surface Adaptor Plate**.
3. Make connections to the supply wires in the junction box according to the “Basic Kit Wiring” diagram on pg 5.
4. Push connected wires into the **Surface Junction box**.
5. Place the **O-Ring** over the **1/4-20 Screw** and insert into the center of the cover plate and tighten. Use **Cap** to cover opening.

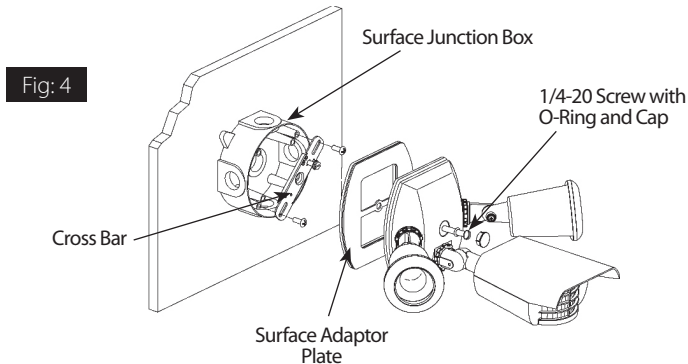

Fig: 4

GT500R KIT MOUNTING (cont'd)

MOUNTING TO RECESSED JUNCTION BOX

1. Discard the **Surface Adaptor Plate** when mounting to a **Recessed Junction Box**.
2. Attach **Cross Bar** to **Junction Box** using the screws supplied. (Fig 5)
3. Make connections to the supply wires in the junction box according to the “Basic Kit Wiring” Fig 8
4. Push connected wires into **Junction Box**.
5. Place the **O-Ring** over the **1/4-20 Screw** and insert into the center of the **Cover Plate** and tighten. Use **Cap** to cover opening.

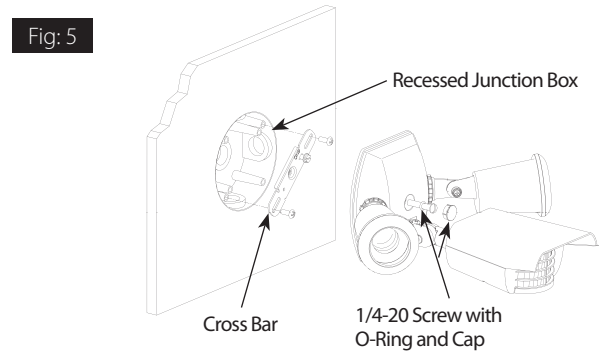

Fig: 5

GT500 SENSOR MOUNTING

GT500 SENSOR WITH SEPARATELY PURCHASED FLOODLIGHTS

1. Mount sensor to 1/2” NPS hole of a RAB CU4 EZ weatherproof coverplate (*not provided*). (Fig 6)
2. Mount fixtures (*not provided*) to coverplate or locate remotely.
3. Wire as shown in “Basic Wiring Diagram” (Fig 9)

Fig: 6



RAB CU4 EZ WEATHERPROOF COVERPLATE

INSTRUCTIONS

GOTCHA® PLUS INSTALLATION



RAB Lighting is committed to creating high-quality, affordable, well-designed and energy-efficient LED lighting and controls that make it easy for electricians to install and end users to save energy. We'd love to hear your comments. Please call the Marketing Department at 888-RAB-1000 or email: marketing@rablighting.com

WIRING

Cautions:

All wiring **MUST** comply with local electrical codes and should be installed by qualified electrician.

Read entire Installation Manual before proceeding.

TURN OFF POWER BY REMOVING POWER FUSE OR TURNING OFF CIRCUIT BREAKER BEFORE INSTALLATION.

Total lighting load to Gotcha must not exceed:

500W @120VAC Tungsten

500W @277VAC Tungsten

600W @120VAC Electronic Ballast (LED)

1350W @277VAC Electronic Ballast (LED)

- Line Carrier Remote Control Systems such as X-10®, Leviton® or Radio Shack® are incompatible with sensors and can cause false activations.
- Do not install on circuits feeding motor loads such as kitchen appliances, HVAC equipment, washer/ dryer or garage door openers.
- Sensor functions best when movement is across its detection pattern, not towards the sensor.
- Mount 6' - 12' high for optimum range and direction.

To switch more wattage, an electrician can install an additional relay.

GT500R KIT WIRING

Easy Wiring Tip:

Use "S" shaped EZ Hang Hook to hold the cover plate and sensor for hands free wiring.

1. Strip incoming supply wires 3/8" to 1/2".
2. Make connections shown left of the dotted line. (Fig 7)
3. The **Red Pigtail** is only used if you are remotely switching additional fixtures.

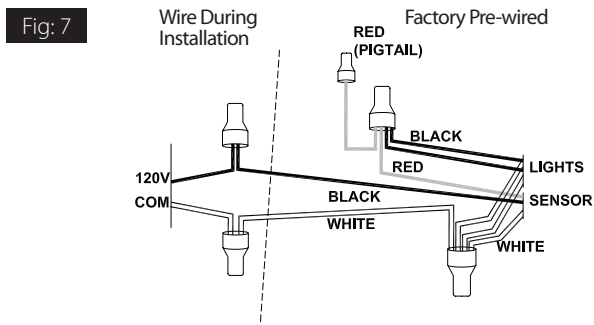

GT500 SENSOR WIRING

Basic Wiring

Strip all wires 3/8" to 1/2" and wire as shown. (Fig 8)

Fig: 8

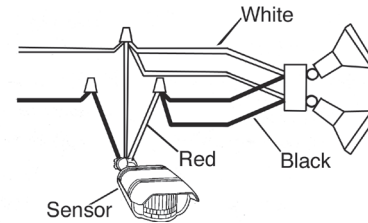

Multiple Fixtures

- Do not switch loads greater than the maximum load rating without installing a relay suitable for your load.
- Wiring more than one sensor together is recommended only for the experienced installer because it becomes difficult to troubleshoot. Single sensors that control their own lights pinpoint movement more accurately and operate better. (Fig 9)

Fig: 9

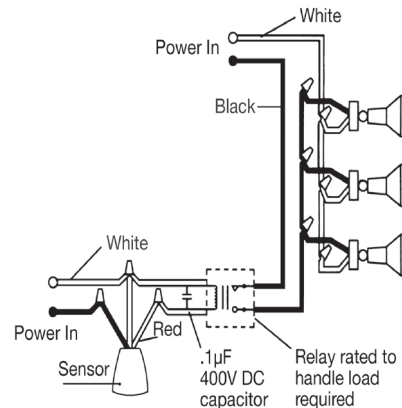

INSTRUCTIONS

GOTCHA® PLUS INSTALLATION



RAB Lighting is committed to creating high-quality, affordable, well-designed and energy-efficient LED lighting and controls that make it easy for electricians to install and end users to save energy. We'd love to hear your comments. Please call the Marketing Department at 888-RAB-1000 or email: marketing@rablighting.com

PICKING A LOCATION

Location Considerations

- Choose a location from which the sensor can “see” all the paths of movement that will be illuminated by its lights.
- If wall mounting, locate 8-10’ high for optimum range and detection. Lower mounting height will reduce range. Sensor must be below and as far as possible away from lights.
- Mount on stable surface that is protected from rain.
- Do not mount on a pole or tree that sways in the wind.
- Sensor functions best when the direction of expected movement is across its detection pattern, not towards the sensor. (Fig 10)

Fig: 10 Detection Pattern

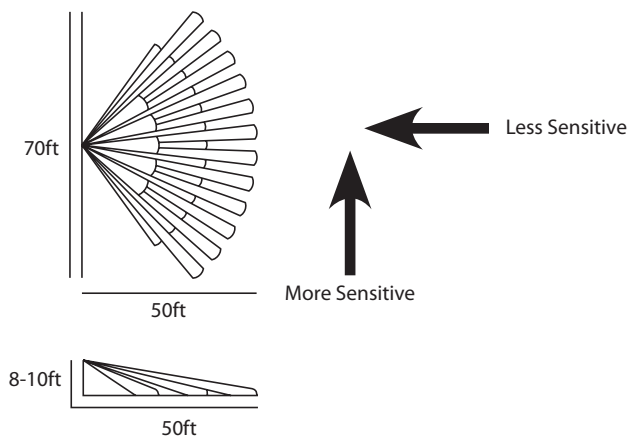

AIMING & TESTING

Test Period:

The sensor has a **Test Mode** which allows it to be aimed and “walk tested” day or night.

- Switch the sensor to **Test Mode** by adjusting the time control to test setting. Power on sensor.
- During the 60 second warm up period, the lights will be turned on. During this time, test that all fixtures and lamps function properly.
- After the warmup period, the sensor will keep lights on for 5 seconds each time it detects movement in its **Detection Zone**.
- Once the **Detection Zone** is tested, adjust the sensor Time control to desired standby time.

WALK TESTING

The purpose of the **Walk Test** is to check and adjust the coverage pattern.

1. Aim the sensor approximately to cover the area you desire.
2. Start outside the **Detection Zone (Fig 11)** and walk across the zone until the lights go on. As distance from the sensor increases, it will take more movement to be detected. For instance, at 10 feet, a half step will be enough, while at 30 feet, several steps will be necessary.
3. To reduce range tilt sensor down. Repeat steps #2 and #3 until you are satisfied with the coverage.
4. After testing is complete, adjust the time setting to desired setting by turning time control knob (5 sec to 15 mins).
5. Your sensor is ready for operation. See the Technical Tips pages if additional help is needed.

Fig: 11

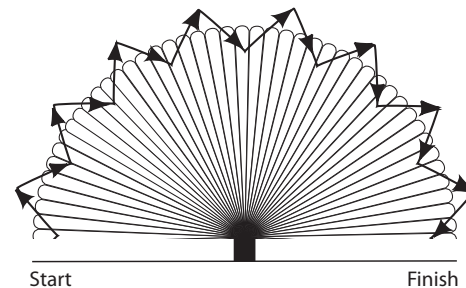

ADJUSTING TIME & SENSITIVITY

Time Control: (Fig 12) Sets the time that lights will remain on after the Detection Zone is vacated. Time setting ranges from approximately 5 seconds to 15 minutes. Turn gently. Do not turn past stops.

Sensitivity: Increases or decreases the responsiveness and range of the sensor.

Fig: 12

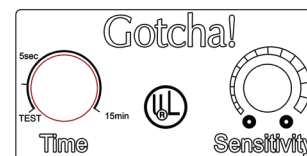

MANUAL OVERRIDE

To keep lights on at night, flip the wall switch two times (OFF-ON-OFF-ON) within 5 seconds. Sensor resets to auto mode after 6 hours. Switch the power ON and OFF once (OFF-ON) quickly to go to AUTO mode. No extra wiring needed.

INSTRUCTIONS

GOTCHA® PLUS INSTALLATION



RAB Lighting is committed to creating high-quality, affordable, well-designed and energy-efficient LED lighting and controls that make it easy for electricians to install and end users to save energy. We'd love to hear your comments. Please call the Marketing Department at 888-RAB-1000 or email: marketing@rablighting.com

TROUBLESHOOTING

LIGHTS DO NOT TURN OFF

1. Make sure sensor is not aimed at something that would move or change temperature such as waving branches, water, air conditioners, windows or heating vents - even on neighboring property. You can test for infrared sources in the area by placing a box or bag over the sensor. Put sensor into **Test Mode**. After the initial 60 seconds of the lights being on, lights should stay off. Wave your hand inside the bag in front of sensor. Lights should go on and then time out. If sensor operates properly when covered, check items 2-6.

Problem: Sensor is triggered by unwanted movement or heat source.

Solution: Tilt sensor or mask lens in the direction of the source. Move sensor or source.

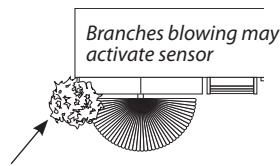

2. Make sure sensor is mounted firmly and does not move even slightly when touched. If it moves, tighten all screws.
3. Make sure that Sensor is not mounted on an unstable object such as a tree or a pole that will move in the wind.
4. Was sensor wired hot? If so, circuitry may have been damaged.
5. Make sure sensor is not aimed within 30 feet of a road.

Problem: Passing cars activate sensor.

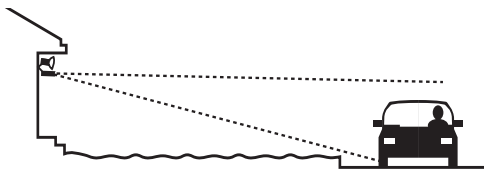

Solution: A 20' safety zone between the sensor and road is recommended to avoid activation from passing cars. You may tilt sensor to not aim in the direction of the street or mask top of sensor lens to reduce range.

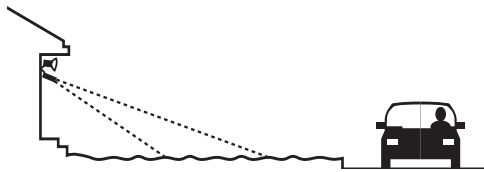

6. Make sure heat from lights is not triggering sensor. Make sure the sensor is below and as far as possible away from lights.
7. Make sure sensor is not in initial 60 sec warm up period. Warm up period will activate every time power is turned off and re-applied to sensor.

LIGHTS DO NOT TURN ON

1. Check that lamps and fixtures work. Compare wiring to the Wiring Diagram in this manual. Check that the power is on.
2. Check that lights from other sources, such as adjacent porch lights, garden lights, streetlights or lights from inside the house are not in the sensor's view. See #1 under "Lights Turn Off Too Quickly".
3. Was sensor wired hot? If so, circuitry may have been damaged.
4. If sensor is painted, make sure there is no paint on the lens and that the lens paint mask is removed.
5. Check that time adjustment control is not set past 15 min mark.

LIGHTS TURN OFF TOO QUICKLY

1. Make sure the **Time Control** is not set to test mode or set to the minimum setting which would be 5 seconds. Change time setting on knob on bottom of the sensor.

RANGE APPEARS LIMITED

1. Check that the sensor is level from side to side and pointed at the area you desire. If unit is tilted, part of the Detection Zone may be high in the air over people's heads.



Solution: Position sensor exactly level from side to side.

2. Check that the sensor is not mounted too high. If mounted above 20 feet, much of the usable range will be lost.

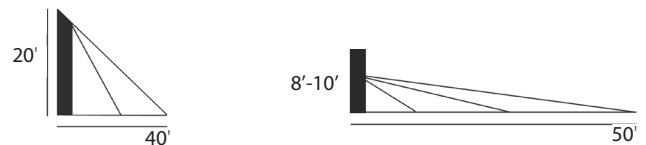

Solution: Mounting at 8' to 10' allows maximum range.

3. If sensor is painted, make sure there is no paint on the lens and that the lens paint mask is removed.

INSTRUCTIONS

GOTCHA® PLUS INSTALLATION



RAB Lighting is committed to creating high-quality, affordable, well-designed and energy-efficient LED lighting and controls that make it easy for electricians to install and end users to save energy. We'd love to hear your comments. Please call the Marketing Department at 888-RAB-1000 or email: marketing@rablighting.com

TROUBLESHOOTING (cont'd)

LIGHTS TURN ON AND OFF INCORRECTLY

1. Make sure the sensor is installed on its own dedicated circuit free of motor loads such as HVAC equipment, kitchen appliances or garage door openers.
2. It is not recommended to wire sensors in parallel. More than one sensor wired together makes them difficult to troubleshoot. Disconnect multiple sensors and test separately.
3. Keep all people completely out of the detection pattern to make sure the sensor is not detecting them.
4. Make sure sensor is located below and as far as possible from its lights. Heat from the lights may trigger the sensor.



Solution: Move sensor below and away from the lights.

5. Make sure lights are not visible from or reflecting back into sensor. Check for white or reflective surfaces close to the sensor.

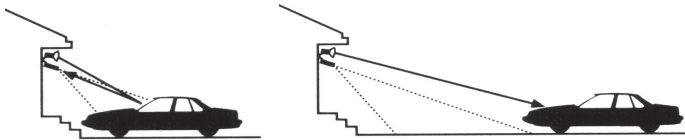

Solution: Aim sensor away from lights and reflective objects or mask the lens in the direction of the light or reflection.

6. Heavy rain, snow or high winds may activate the sensor occasionally.

Solution: Reduce sensitivity control settings, mount in a more protected area and/or mask the lens if this is a constant problem.

TROUBLESHOOTING (cont'd)

7. Make sure sensor is not aimed within 30' of a road or sidewalk. Passing cars will activate sensor.

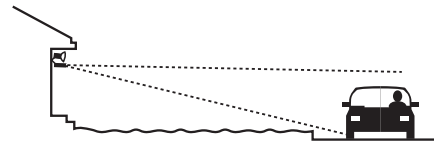

Solution: Mask the top of the lens to reduce Detection Pattern Length.

8. Self ballasted PL lamps may cause cycling (*on-off*).
9. Check solutions 1, 2, 3, 5 & 6 under "Lights Do Not Turn Off" (*Pg. 5*).

TOLL-FREE TECHNICAL ASSISTANCE

If you need technical assistance, please do the following:

1. Re-read the **Technical Tips** sections of this manual.
2. Call the Tech Help Line at 888 722-1000, 8AM to 4PM Eastern Time M-F and we will be glad to help you. Before you call, please have the following information handy:
 - Catalog number of your unit;
 - Wattage, types and locations of lights connected to the sensor;
 - The electrical circuit on which the sensor is installed... what else does it feed? How is the sensor power switched?
 - This installation manual.

Note: RAB Lighting cannot give electrical wiring instructions by phone. Please consult a qualified electrician.

Note: These instructions do not cover all details or variations in equipment nor do they provide for every possible situation during installation operation or maintenance.



Easy Answers

rablighting.com
Visit our website for product info

Tech Help Line
Call our experts: 888 722-1000

e-mail
Answered promptly - sales@rablighting.com

Free Lighting Layouts
Answered online or by request