

LIST OF PARTS

DESCRIPTION	MATERIAL	FINISH
COVER	STEEL	GALVANIZED
SCREWS	STEEL	GALVANIZED

#6-32 X 7/16" COUNTERSINK
MACHINE SCREWS (QTY. 4)

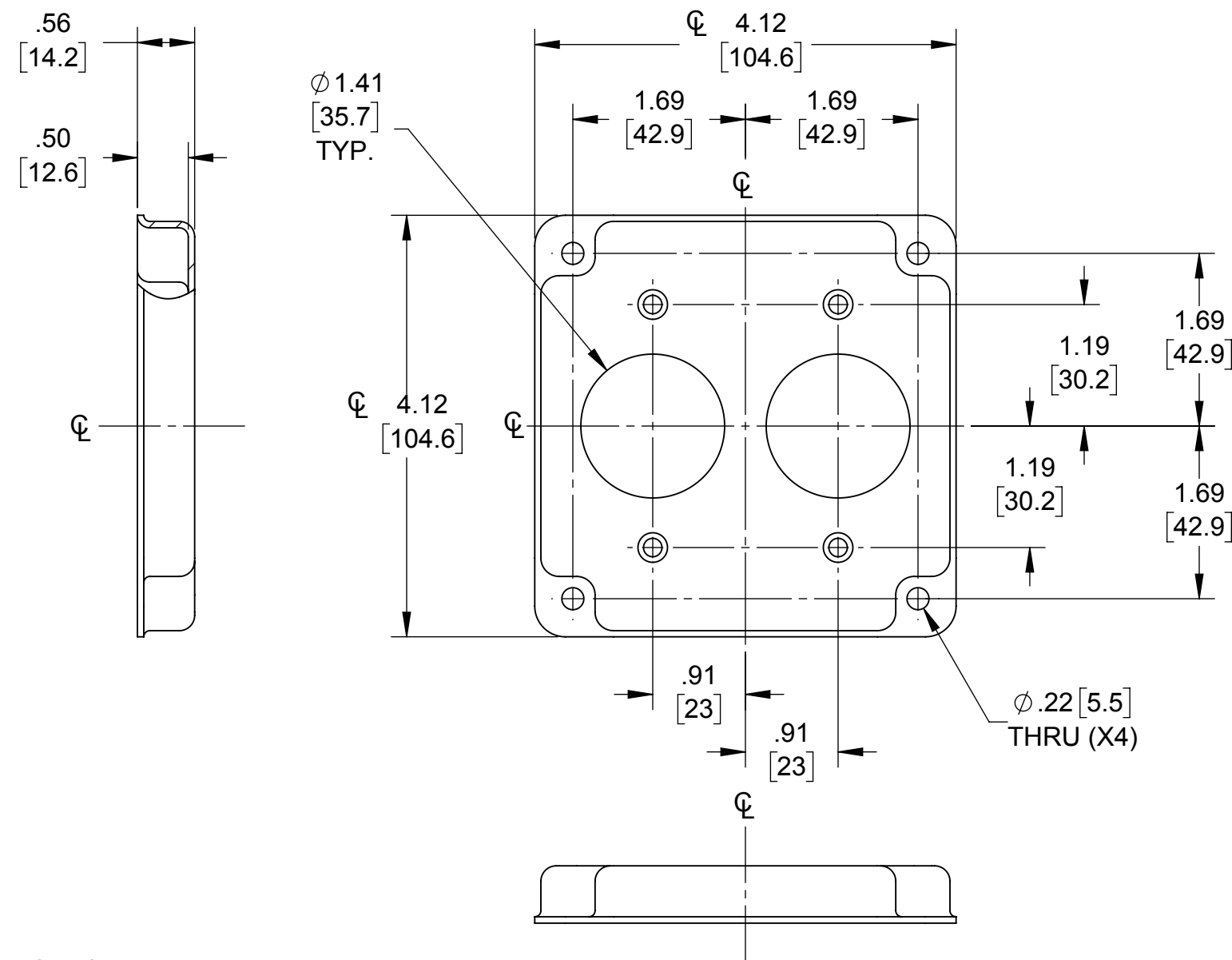
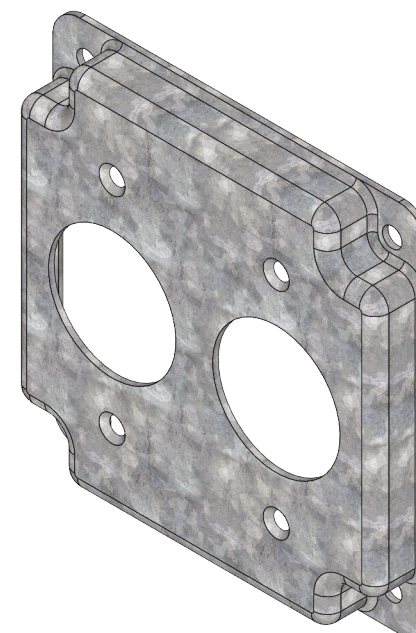
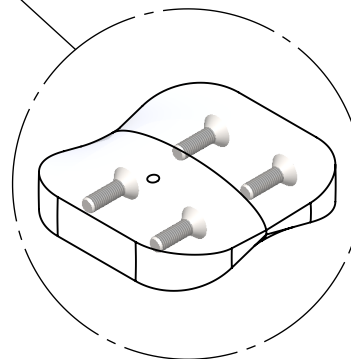

- NOTES:
1. ALL DIMENSIONS ARE IN INCHES AND [MILLIMETERS]
 2. BOX VOLUME: 6.5 IN³ [107] CM³
 3. UL LISTED

INITIAL RELEASE	N.S.	03-30-17
SYM.	REVISION DESCRIPTION	APP DATE

THE DESIGN AND DIMENSIONS OF THE PRODUCT SHOWN ON THIS DRAWING ARE SUBJECT TO CHANGE WITHOUT NOTICE

TITLE:
**4" SQ. CRUSHED CORNER COVER, (2)
RECT 1.406"**

TOLERANCE UNLESS OTHERWISE SPECIFIED

.XX DECIMAL $\pm .015$
.XXX DECIMAL $\pm .005$
ANGLE $\pm 2^\circ$

RACO
South Bend, Indiana

DRAWN BY:	RMV	SCALE:
APP. BY:	N.S.	1:1.5
DATE:	03-30-17	