

LIST OF PARTS

| DESCRIPTION | MATERIAL | FINISH |
|-------------|----------|------------|
| SPACER | STEEL | GALVANIZED |
| SIDES | STEEL | GALVANIZED |
| FASTENERS | STEEL | GALVANIZED |
| | | |
| | | |
| | | |
| | | |
| | | |

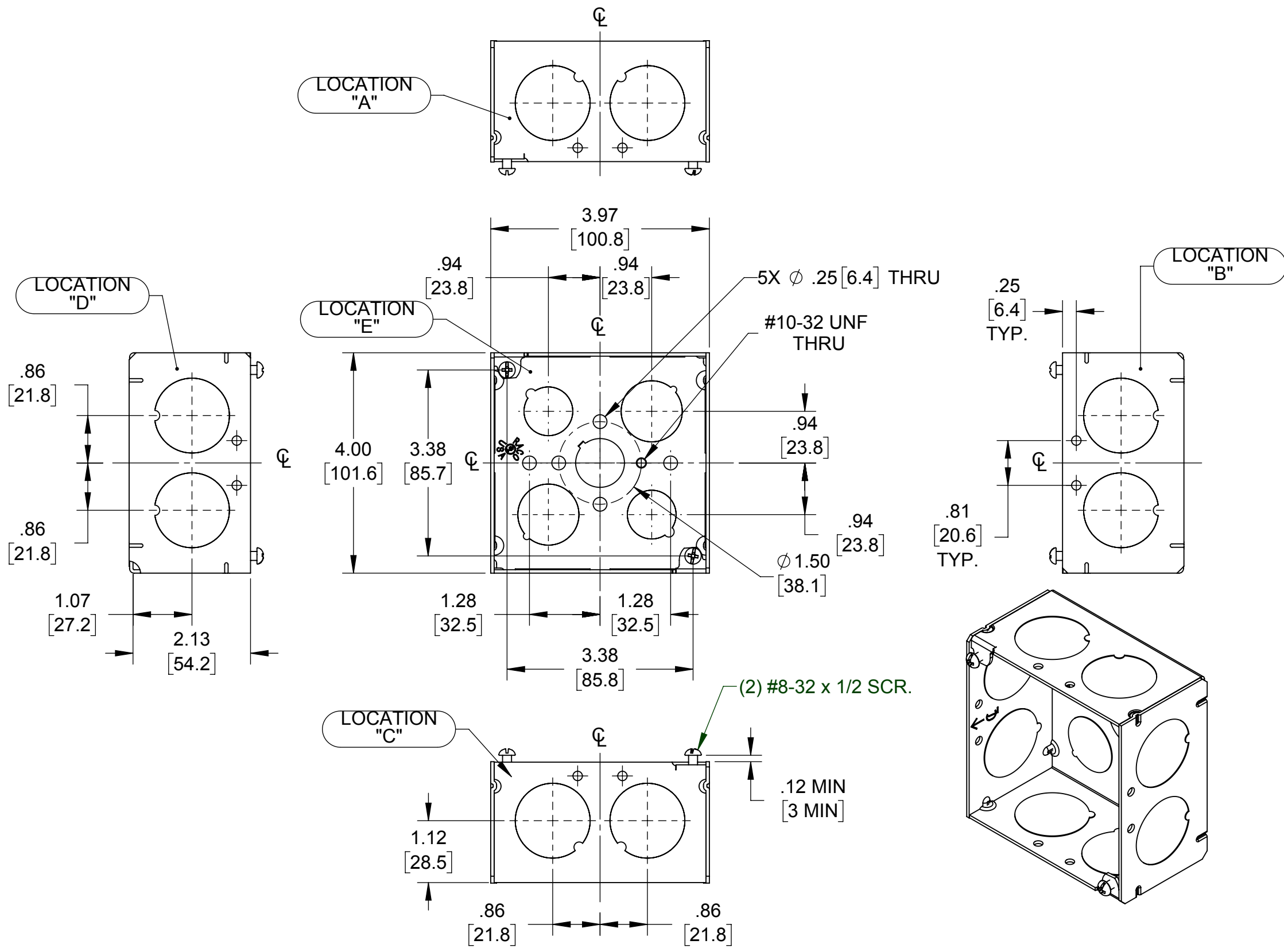

- NOTES:**
1. ALL DIMENSIONS ARE IN INCHES AND [MILLIMETERS]
 2. BOX VOLUME: 30.3 IN³ [496.5 CM³]
 3. UL LISTED

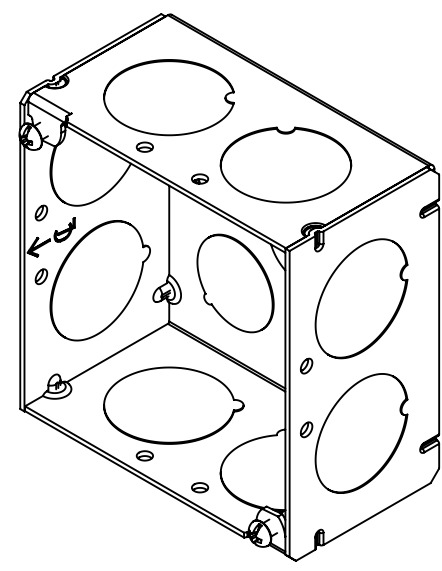

| KNOCKOUTS | | |
|------------|---------------|------|
| TRADE SIZE | LOCATION | QTY. |
| 1/2" KO | E | 2 |
| 3/4" KO | A, B, C, D, E | 2 |

| INITIAL RELEASE | N.S. | 03-10-17 |
|-----------------|----------------------|----------|
| SYM. | REVISION DESCRIPTION | APP DATE |

THE DESIGN AND DIMENSIONS OF THE PRODUCT SHOWN ON THIS DRAWING ARE SUBJECT TO CHANGE WITHOUT NOTICE

TITLE:
4" SQ. 2-1/8" DEEP WELDED BOX

TOLERANCE UNLESS OTHERWISE SPECIFIED
.XX DECIMAL ±.015
.XXX DECIMAL ±.005
ANGLE ±2°

RACO
South Bend, Indiana

| | | | |
|-----------|----------|--------|-----|
| DRAWN BY: | RMV | SCALE: | 1:2 |
| APP. BY: | N.S. | DATE: | |
| DATE: | 03-10-17 | | |