



**SMARTWIRE®**  
ELECTRONIC SIGN BALLASTS

**KTSB-E-2048-46-UV-S**

**DESCRIPTION**

4-6 Lamps | T8HO or T12HO | 20'-48' Combined Lamp Length | Series Wiring



<b>STARTING METHOD:</b> Programmed Rapid Start
<b>INPUT VOLTAGE:</b> 120-277VAC ±10%
<b>LAMP CONNECTION:</b> Series
<b>INPUT FREQUENCY:</b> 60Hz

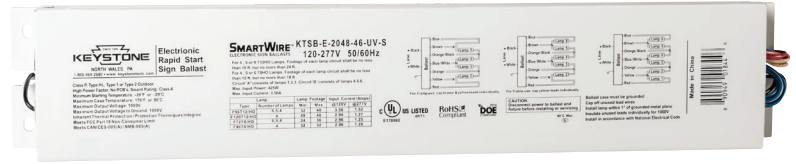

**PRODUCT FEATURES**

- Sound Rated: A
- Minimum Starting Temperature: -20°F, -29°C
- Maximum Case Temperature: 176°F, 80°C
- Meets FCC Part 18 (Class A) Non-Consumer Limits
- UL, cUL 935 Listed, Class P, Type 2 Outdoor, Type HL

**ELECTRICAL SPECIFICATIONS**

Lamps		Lamp Footage		Input Voltage	Max Input Watts	Nominal Line Amps	Power Factor	Harmonic Total	Crest Factor
Type	Number of Lamps	Min.	Max.						
T12HO	6,5,4	20	48	120	435	3.65	> 0.90	< 10	< 1.7
		20	48	277	420	1.52	> 0.90	< 10	< 1.7
T8HO	6,5,4	20	36	120	390	3.25	> 0.90	< 10	< 1.7
		20	36	277	385	1.39	> 0.90	< 10	< 1.7

**LAMP FOOTAGE**

Lamp Type	Minimum	Maximum
T12HO	20'	48'
T8HO	20'	36'

**MECHANICAL SPECIFICATIONS**

**CASE DIMENSIONS**

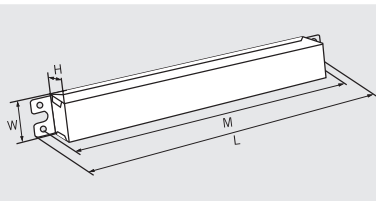

<b>LENGTH</b>	16.7"
<b>WIDTH</b>	3.15"
<b>HEIGHT</b>	1.18"
<b>MOUNTING</b>	15.95"
<b>CASE STYLE</b>	L31

**STANDARD LEAD LENGTHS\***

<b>WHITE</b>	25"
<b>BLACK</b>	25"
<b>RED</b>	72"
<b>YELLOW</b>	72"
<b>BLUE</b>	72"
<b>ORANGE</b>	72"
<b>ORANGE/BLACK</b>	72"
<b>BROWN</b>	72"
<b>BLUE/WHITE</b>	72"

Lead wires are 18 AWG 105°C/600V, solid copper.

**CASE MATERIAL:** Metal

\*Consult Keystone for special lead length requirements.

**FOR INSTALLATION PURPOSES**

Ballast consists of two lamp circuits - Circuit A and Circuit B. Circuit A consists of lamps 1, 2, 3 and Circuit B consists of lamps 4, 5, 6.

- Each lamp circuit can drive 2 or 3 T12HO lamps in any combination from 10'-24'.
- Each lamp circuit can drive 2 or 3 T8HO lamps in any combination from 12'-18'.

Each lamp circuit should be balanced with equal lamp load (footage).

**WIRING DIAGRAMS**

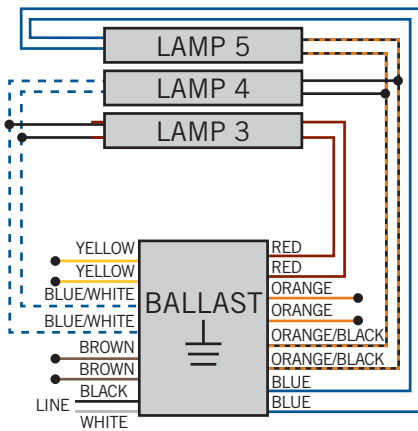

Three Lamp Application, Cap Off  
Unused Leads Individually,  
Insulate to 600V

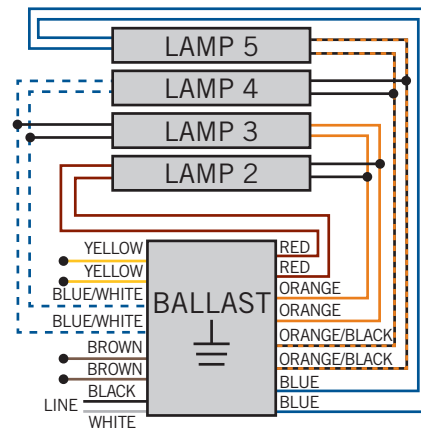

Four Lamp Application, Cap Off  
Unused Leads Individually,  
Insulate to 600V

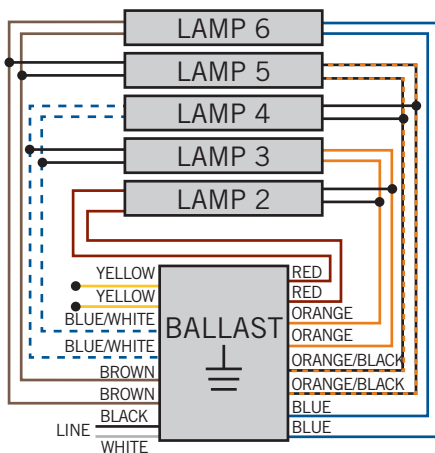

Five Lamp Application, Cap Off  
Unused Leads Individually,  
Insulate to 600V

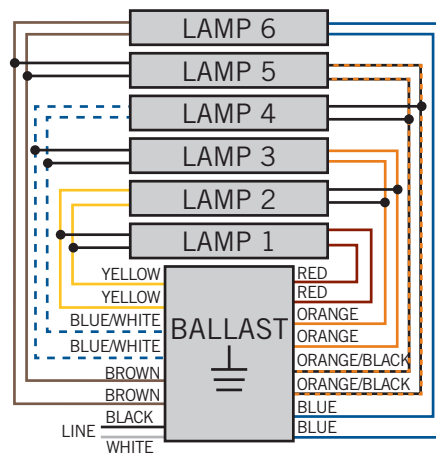

Six Lamp Application



**SMARTWIRE**<sup>®</sup>  
ELECTRONIC SIGN BALLASTS

**KTSB-E-2048-46-UV-S**

**ORDERING INFORMATION**

ORDER CODE	PACKAGING STYLE	PACK QTY.	ITEM STATUS
KTSB-E-2048-46-UV-S-IP	Individually Packaged	1	Quick Ship

**CATALOG NUMBER BREAKDOWN**

**KT S B - E - 2 0 4 8 - 4 6 - U V - S - I P**

- 1** Keystone Technologies Sign Ballast
- 2** Electronic
- 3** Minimum Total Lamp Length\*
- 4** Maximum Total Lamp Length\*
- 5** Minimum Number of Lamps
- 6** Maximum Number of Lamps
- 7** 120-277V Input
- 8** SmartWire
- 8** Packaging Style

\*Minimum and maximum total lamp length based on T12HO lamps.